

HIGH CAPACITY PUMPER INSTRUCTIONS

H.E. Anderson Company is dedicated to assisting our customers with installation and use of our products. Our technical staff are available each weekday from 8:30 AM to 12:00 PM, and 1:00 PM to 4:30 PM central time. You may call us toll free at 1-800-331-9620 from anywhere in the U.S.A. and Canada. If no one is available, we will promptly return your call. You may also contact us via e-mail at sales@heanderson.com.

Unpacking: Please open and inspect your package upon receipt. Your package was packed with great care and all the necessary packing materials to arrive to you undamaged. If you do find an item that is broken or damaged, you must contact the delivering carrier to report the claim.

If you need an additional owners manual for any H.E. Anderson Company product, please visit our website at www.heanderson.com/resources.

Before you call, review this manual. You may find the answer to your question here. But if not, reviewing the manual will help us to help you. You should have the Pumper model number and date code available when you call. See photo below for their locations.

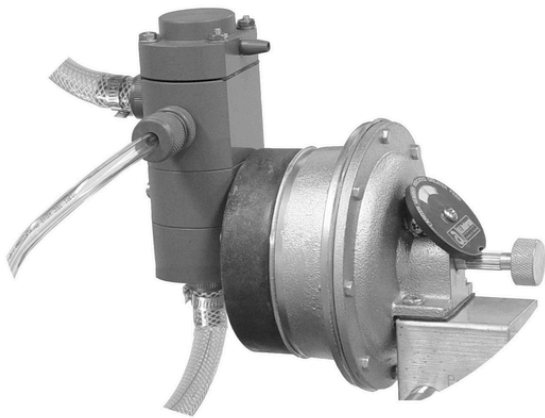

H4 Pumper with VMC3 Valve Module



The model and serial number of each pump are located under the control shaft



H.E. Anderson
COMPANY
P.O. Box 1006
Muskogee, OK 74403
918.687.4426

We manufacture pumpers (pumpheads) of two types; standard capacity and high capacity. These instructions apply specifically to high capacity pumpers and chemical fittings using 1/2" I.D. (5/8" O.D.) tubing.

Pumpers can be used individually or on a multi-pumper manifold with additional high capacity pumpers. You should have separate instruction manuals for other components of your system such as control units, flow meters, and accessories.

Special attention is required to get maximum performance from units with high capacity pumpers. They are the same physical size as standard pumpers, having the same stroke capacities. However, they have much larger chemical check valves and injection fittings. This allows the pumps to operate at 40 strokes per minute with no loss of injection rate.

Some people prefer to plumb the suction line using rigid PVC pipe. If you will be doing this, you should use 3/4" or larger pipe. Be sure to install a shutoff valve (3-way for drain) and an in-line strainer with plenty of area. Y type strainers are okay. The strainer should have 5 GPM or greater flow capacity. Plumbing of the flow meter and tee(s) for the injection point fitting(s) should be completed before installing the pumper(s).

SET-UP

Each pumper is calibrated under actual operating conditions at the factory. Occasionally the dial scale gear will become disengaged in shipment, or by rough handling. If this has happened, follow the procedures in the PUMPER CALIBRATION section once you have completed the set-up.

Pumper Installation

There are two ways of installing the pumper.

- On a multi-pumper manifold by mounting to a multi-adapter,
- Mounting directly to a type AS pilot valve,
- Mount the pumper using the rectangular gasket and two 1/4-20 x 1/2" stainless steel pan head screws.

VMC3 Chemical Valve Module

The VMC3 (P/N 20976) is a multi-featured module which includes the following features and functions:

- Chemical suction valve
- Chemical discharge valve
- Priming vent for easy priming
- Anti-siphon protection for negative pressure occurrences.
- Protection against positive suction line pressures up to 7.5 PSIG.
- Standard ball poppets are stainless steel, with ceramic available as an extra cost option.

For each pumper:

- Install the VMC3 valve module using one (P/N 01686) O-ring and two 1/4-20 x 2 1/2 inch stainless steel screws.
- Cut a length of 1/2" I.D. braided hose for the suction line.
- Slide two stainless steel hose clamps onto the hose and install the suction line hose.
- Secure with the hose clamps. Do not depend on the hose itself to maintain an air/chemical leak-free connection.
- The VMC3 valve module also has a leakage drain. Liquid will come out this drain only when the internal diaphragm ruptures. You may also attach a tube to this drain.



Attaching tubes to the priming vent and leakage drain is especially important when pumping hazardous chemicals.

Injection Point Fitting (IPF)

- The IPF is threaded for either ½" or 1" fittings.
- Refer to the 2" installation photo in the front of this manual as needed.
- The IPF should be installed with chemical flowing up, as nearly vertical as practical, and never more than 45° from vertical.
- Connect a cut-to-length piece of tubing between the discharge valve and the injection point fitting. Avoid any sharp bends that might collapse into a kink.
- Secure both ends with hose clamps.

PRIMING

High capacity pumpers will normally prime themselves within a few pump strokes in operation. If the pumper does not self-prime do the following.

- Refer to Fig. 1 for this procedure
- Attach a ¼" I.D. Hose to the priming vent outlet. Run the other end to a container to catch any chemical vented during priming.
- With the metering pump operating, open the priming vent about one turn. The pump will be pumping to atmosphere.
- As soon as chemical come from the drain, close the priming vent by hand. Do not use a wrench; you can damage the seat.
- The system is now ready to operate.

MAINTENANCE

Normally the pumper should require little maintenance. This, however, depends on the quality and cleanliness of the chemical being pumped.

- The pumper should be inspected at regular intervals for proper operation and leaks.
- Check valve module for cleanliness, chemical attack, and scale build-up.
- At some point the O-rings and diaphragms may have to be replaced. Refer to the parts drawing in the rear of this manual when servicing these valves.
- Periodically remove and inspect the injection point fitting. If scale is found, clean it off and establish a regular schedule for checking the fittings.
- Check to be sure all pumpers are properly primed after servicing.

STORAGE

If the injector will not be used for a long period:

- Remove it from service.
- Flush the pumper and chemical check valves with water, or other suitable cleansing solution, either by pumping water through the unit (if not feeding acid) before removing it or by rinsing these parts after removal.
- Tape the valve openings closed while still wet. This will protect the seals and prevent insects from plugging up the openings.



Protect the entire system from freezing temperatures. Our warranty does not cover freeze damage.

PUMPER AND DIAPHRAGM PROBLEMS



Do not disassemble the pumper cylinder until testing and trouble shooting indicate that you need to do so. There is normally very little maintenance or service required internally.

If your feeder has a clear acrylic head, you will be able to see inside the diaphragm chamber. If you have the gray or black head, you will have to rely on external checks to determine problems which might develop inside the chemical chamber. Few things can go wrong in the chemical chamber, and they are easily checked.

Problems With Chemicals

- Some chemicals may not be compatible with the pumper diaphragm. You should check compatibility of a chemical with the diaphragm material before pumping. Because we do not have control of what chemicals you pump, we do not warrant diaphragms or plastic heads against chemical attack.
- Some chemicals can attack the diaphragm or head, causing it to stick to the head. When this happens it will not pump.
- Changing chemicals without flushing the head can sometimes cause a chemical reaction which can damage the diaphragm, plastic head, or fittings.
- Wetttable powders sometimes cake up inside the head. This reduces the pumping capacity. If your unit does not appear to pump as much as it should, check the calibration. You may need to remove and clean the plastic head.

Problems With Diaphragms

The most common problem with pumpers other than faulty check valves is a ruptured diaphragm. A ruptured diaphragm will cause drainage out the drain hole in the bottom of the cylinder. If the chemical side diaphragm has ruptured chemical will drain from the hole. If the water side diaphragm has ruptured water will drain.



It is very important that you replace a ruptured chemical side diaphragm immediately. If you do not, the chemical will attack the back side of the water side diaphragm causing it to also fail.

The spring and other parts in the cylinder can also be affected. Prompt attention can save added expensive repairs. A ruptured water side diaphragm should also be fixed as soon as possible, but it is not nearly as critical as the chemical side diaphragm.

Changing the Chemical Side Diaphragm

- Remove the chemical check valves. Use a pan to catch the chemical which might be spilled when the plastic pump head is removed.



Use precautions when dangerous chemicals are being pumped; here you should remove the chemical check valves and wash the pump head to remove any remaining chemical. Use baking soda to neutralize acid.

- Refer to the exploded view parts drawings in the rear of this manual for the following steps.
- Remove the screws and plastic pump head.
- You may have to use a thin blade screwdriver several places to free the diaphragm from the head and cylinder.
- Turn the stroke adjusting knob until the dial reads 7 or less.
- Now unscrew and remove the diaphragm.
- Before installing the new diaphragm, coat the threads of the threaded stud (5) with an anti-seize lubricant to prevent sticking to the aluminum diaphragm insert.

- Screw in the new diaphragm until it just touches the water side diaphragm. If the holes in the diaphragm do not line up with the holes in the cylinder (6), unscrew the diaphragm until they line up.
- Set the dial to 10, align the valve holes in the plastic head so the head is vertical, and reinstall the plastic head.
- After changing a diaphragm check the calibration of pumper.
- Recalibrate it if necessary. See Pumper Calibration Instructions for this procedure.

Changing the Water Side Diaphragm

Before disassembling the pumper, mark the brass flange and cylinder so you can reassemble them in the same positions. (Refer to the exploded view parts drawing in the rear of the manual.)

- To change the water side diaphragm (2) first remove the chemical side diaphragm (See previous heading).
- Place the small end of the cylinder face down on your work bench.
- Remove all but two screws, which should be opposite each other.
- There is a spring with about thirty pounds force pushing the diaphragm against the flange. Carefully follow the following procedure to remove the flange from the cylinder. Support the flange with your hand as the last screws are removed. This will prevent damage to the threaded holes and also prevent the pieces from flying apart.
- To reassemble, place the cylinder, large end up, on your workbench.
- Place the large end of the spring into the cylinder. If you have a low pressure pumper, place the spring guide (P/N 10009), then the spring (P/N 09995) into the cylinder.
- Next, lay the water side diaphragm on the flange.
- Place all the screws through the flange and diaphragm.
- Align the marks you made on the cylinder and flange. (If you did not mark the pieces, the cylinder has a drain hole which is at the bottom. Match this drain hole to the bottom of the flange.)
- Place the flange/diaphragm assembly onto the spring, push the flange and diaphragm down and start all the screws in their holes. Screw the screws down evenly; take care to be sure the flange goes into position without “cocking.” Then tighten all screws securely. Replace the chemical side diaphragm (See previous section).

STROKE SHAFT SERVICING

To replace the O-ring shaft seal the flange must be removed from the cylinder. Before disassembling the pumper, mark the brass flange and cylinder so you can reassemble them in the same positions.

- Carefully remove the screws from around the edge of the flange.



Do not leave the cylinder assembly open after the flange has been removed. Place a weight of at least thirty pounds on the exposed diaphragm to hold it in the cylinder. This will prevent damage to the chemical side diaphragm.

- Unscrew the screw holding the pad (4) to the stroke shaft (3). You may now unscrew the shaft and remove it from the flange.
- If the seal was leaking, inspect the bore in the flange. If the hole is badly damaged, the flange will have to be replaced.
- Check the O-ring for tears or nicks.
- When replacing the O-ring, be very careful when stretching it over the threads. You may find it easier to wrap the threads with tape before sliding the O-ring into position; then removing the tape.
- Lubricate the O-ring, shaft, and hole with a silicone lubricant (such as Dow Corning #111 silicone grease).
- Reinstall the shaft and replace the pad. Screw the pad retaining screw in just enough to allow the pad to revolve, but have no end play.



Over tightening the screw may cause the shaft to expand, making it difficult or impossible to adjust the chemical feed. Reassemble the pumper according to the procedure in the last paragraph in the previous section.

20976 VMC3 Module (Check Valve)

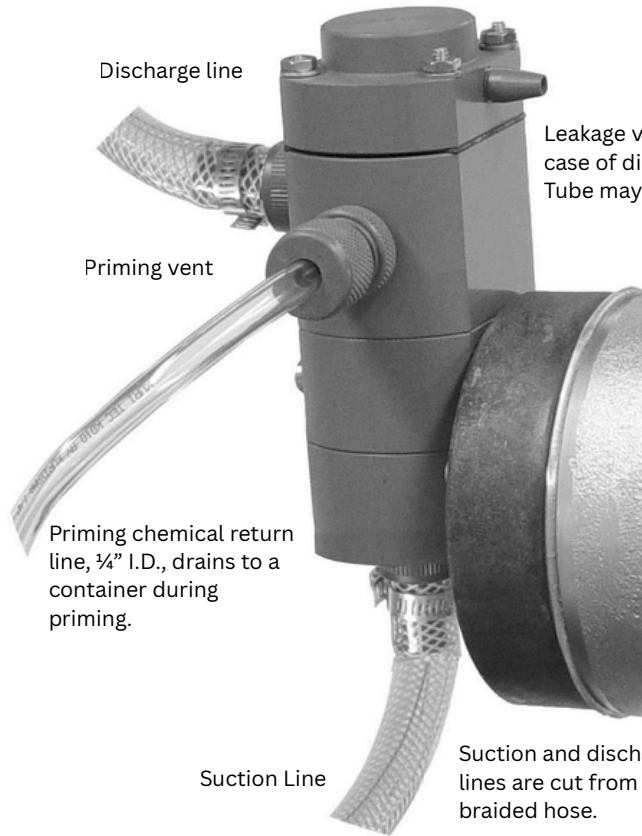

Leakage vent will drain chemical in case of diaphragm failure. A ¼" I.D. Tube may be attached here.

Priming chemical return line, ¼" I.D., drains to a container during priming.

Suction and discharge lines are cut from ½" I.D. braided hose.

21209 VMC IPF (Injection Point Fitting)



Nozzle Options:
20818 - 1.5".....for 1" Tee
20826 - 2".....for 1-1/2" Tee
20834 - 3.25".....for 2" Tee
20842 - 4".....for 3"&4" Tee
20850 - 5.5".....for 6" Tee

20976 VMC3 Vallve Module Parts Diagram

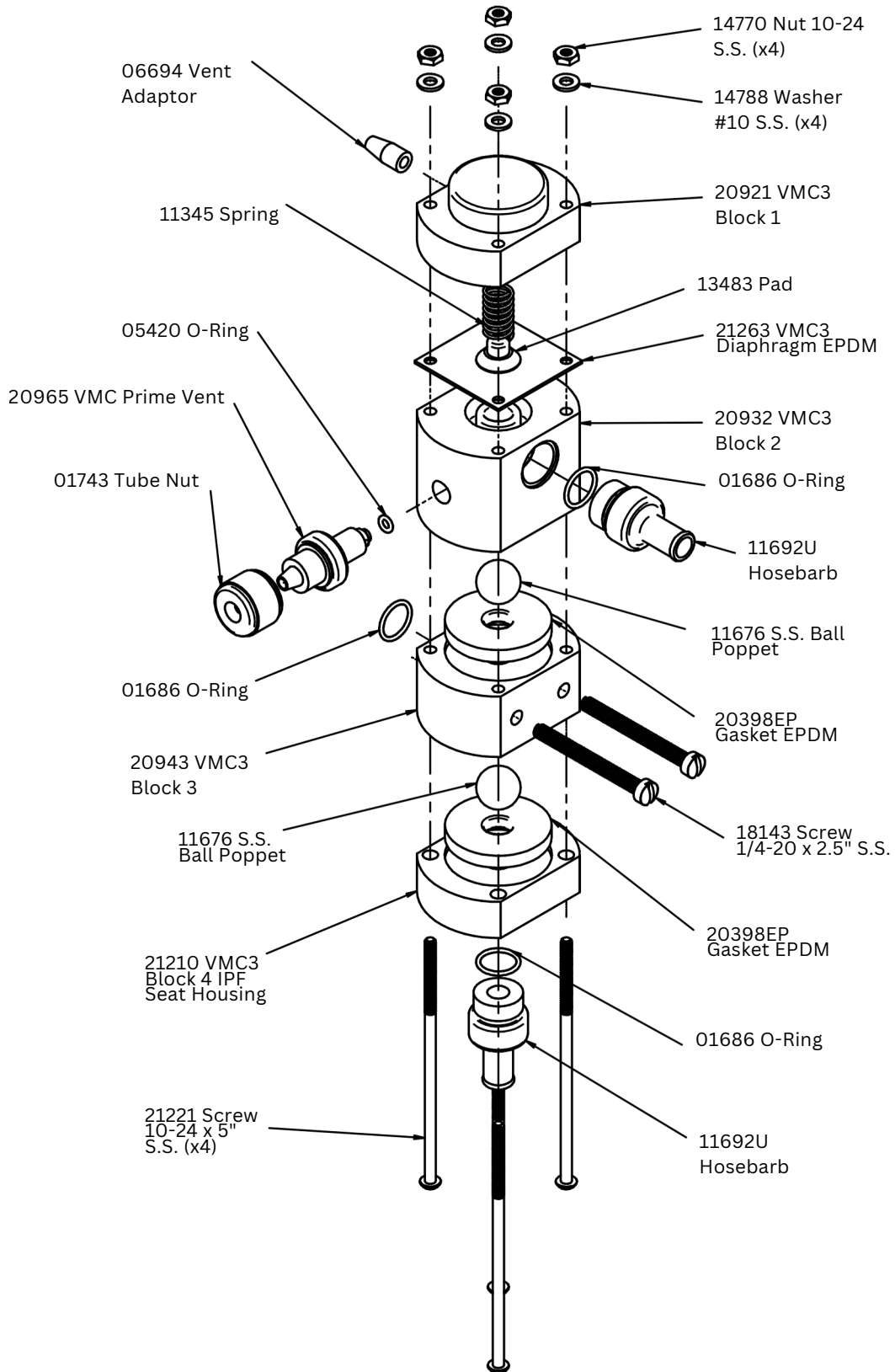

21209 VMC3 IPF Parts Diagram

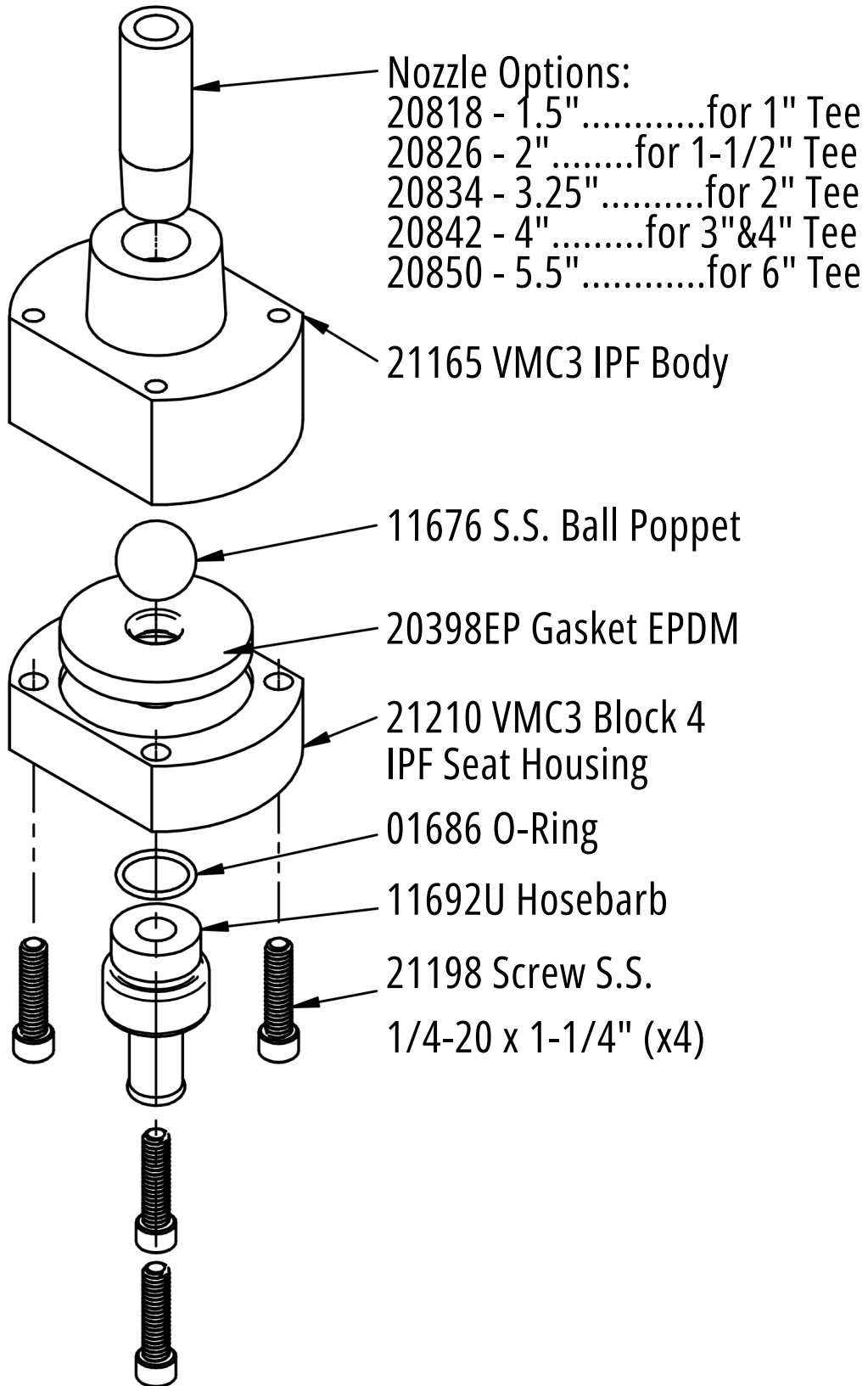

H4 or P4 PUMPER ASSEMBLY

FOR SERIAL NO. OK016B AND LATER

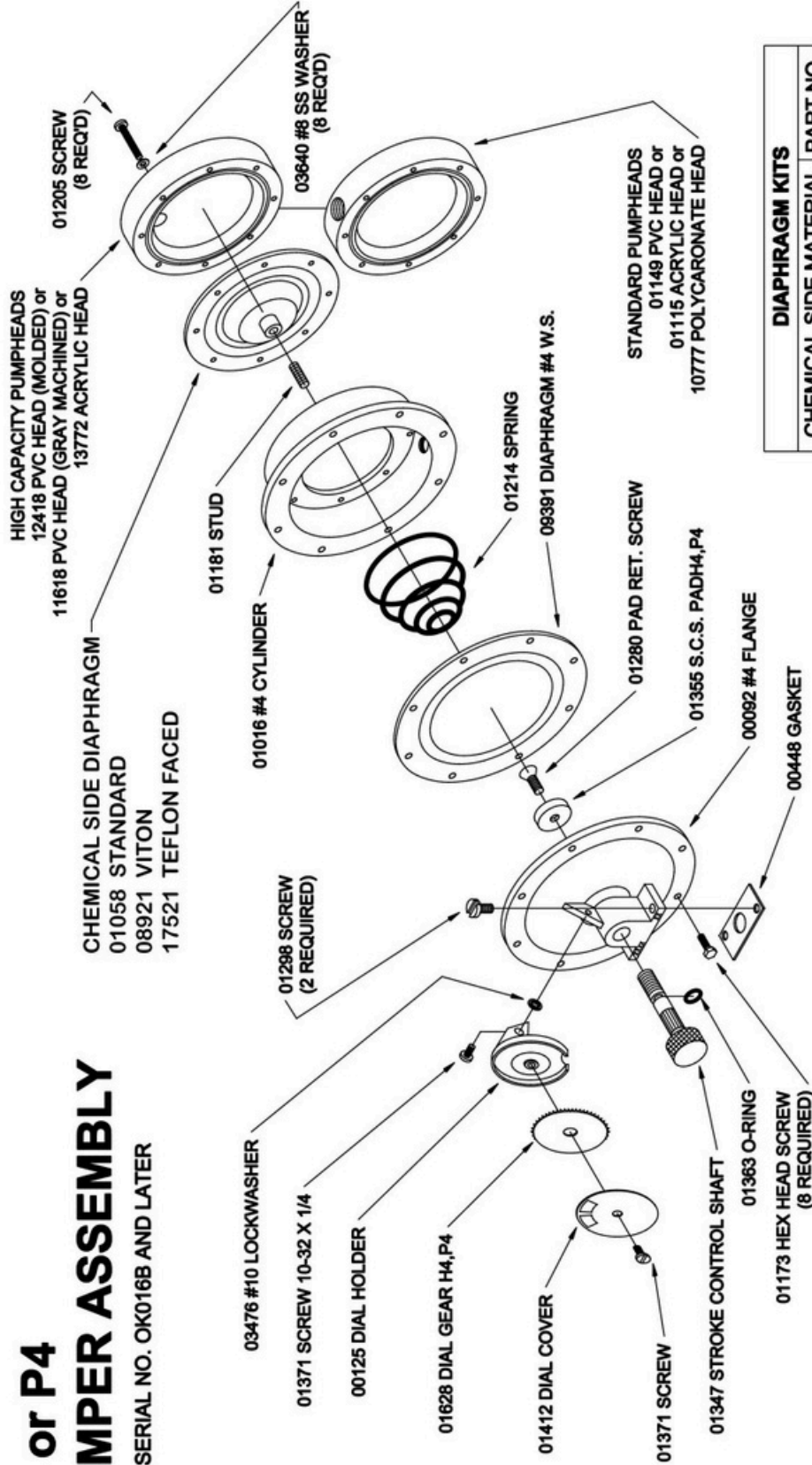

| DIAPHRAGM KITS | |
|------------------------|----------|
| CHEMICAL SIDE MATERIAL | PART NO. |
| STANDARD (EPDM) | 08939 |
| VITON | 08921 |
| TEFLON FACED | 18932 |

| PUMPERS COMPLETE (ALL PARTS ON PAGE) | | | |
|--------------------------------------|---------|---------|---------|
| | STD/PVC | STD/ACR | TEF/PVC |
| P4 | 46510 | 46509 | |
| H4 | 46554 | 46543 | 46587 |

H4P4

HI, H2, P1, or P2 PUMPER ASSEMBLY

LESS LIQUID END FITTINGS

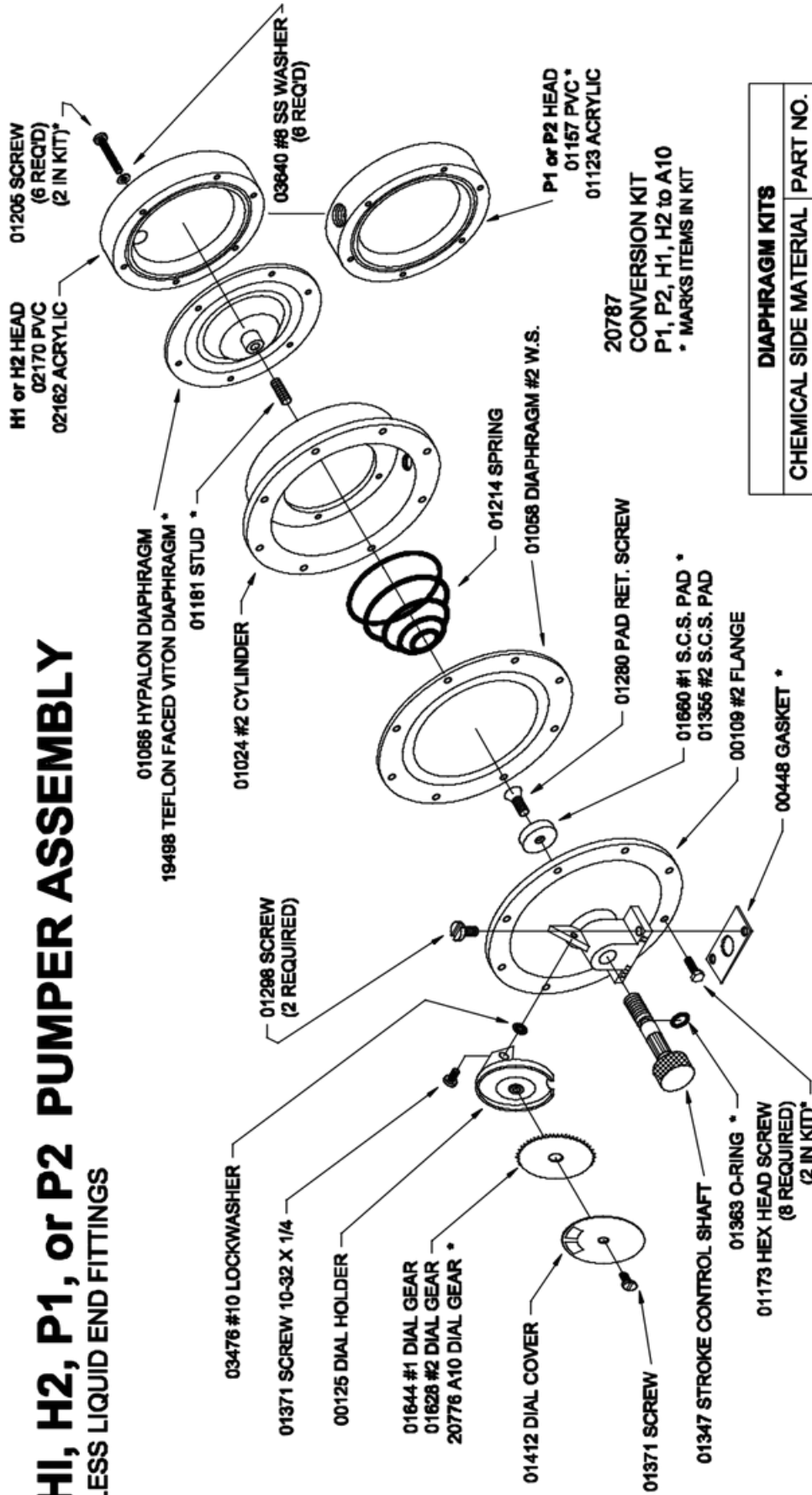

| DIAPHRAGM KITS | |
|------------------------|----------|
| CHEMICAL SIDE MATERIAL | PART NO. |
| HYPALON | 08913 |

DIAPHRAGM KITS INCLUDE BOTH DIAPHRAGMS, STUD ALL O-RINGS, GASKETS AND 2 EACH EXTRA SCREWS

| PUMPERS COMPLETE (AS SHOWN ON THIS PAGE) | | | | |
|--|-------|-------|-------|-------|
| | P1 | P2 | H1 | H2 |
| HYP/PVC | 45510 | 46010 | 45554 | 46054 |
| HYP/ACR | 45509 | 46009 | 45543 | 46043 |

H.E. ANDERSON COMPANY LIMITED WARRANTY

WHAT IS COVERED

The H.E. Anderson Company of Muskogee, Oklahoma, will make any necessary repairs and/or replace any parts of this H.E. Anderson Company product made necessary because of defects in materials or workmanship for fifteen months from date of manufacture. Warranty repairs and/or replacements will be performed without charge to the owner by H.E. Anderson Company within a reasonable time after prepaid delivery of the defective product to the H.E. Anderson Company, 2100 Anderson Drive, Muskogee, Oklahoma 74403.

WHAT IS NOT COVERED

This warranty specifically excludes failure of any parts or materials caused by chemical attack or damage caused by operation above rated capacity or pressure. Further, this warranty does not cover wear or failure caused by sand or other foreign materials which may be found in water that is passed through our products, or damage caused by freezing or exposure to water temperatures above 60°C (140°F).

This warranty does not cover damage caused by failure to follow prescribed installation instructions and limitations issued by H.E. Anderson Company. In addition, this warranty does not cover service adjustments, repairs, or replacements caused by misuse, negligence, alteration, accident, or lack of specified maintenance.

This warranty does not cover components used by, but not manufactured by H.E. Anderson Company, in the manufacture of our products except to the extent of said component manufacturer's warranty.

This warranty specifically excludes liability for consequential damages or for charges for labor or expense in making repairs or adjustments, or losses of time or inconvenience. This warranty gives you specific legal rights and you may also have other legal rights which may vary from state to state. H.E. Anderson Company does not authorize any person to create for it any other obligation or liability in connection with these products. ANY IMPLIED WARRANTY APPLICABLE TO THESE PRODUCTS IS LIMITED TO THE DURATION OF THIS WARRANTY. H.E. Anderson Company shall not be liable for consequential damages resulting from breach of this written warranty.

NOTE: Some states do not allow limitation on how long an implied warranty will last or the exclusion of limitations of incidental or consequential damages, so the above limitations or exclusions may not apply to you.

WHAT TO DO IF THERE IS A QUESTION REGARDING WARRANTY

- 1) Promptly notify the consumer adviser at H.E. Anderson Company by telephone at 800-331-9620 or 918-687-4426.
- 2) Confirm the report in writing (or via FAX at 918-682-3342) to the H.E. Anderson Company, stating the circumstances surrounding the problem.

PURCHASER'S OBLIGATION

- a) Purchaser must give H.E. Anderson Company immediate written notice on discovery of defect.
- b) Purchaser must pay for shipment of the defective product to the H.E. Anderson Company, 2025 Anderson Drive, Muskogee, Oklahoma 74403.



H.E. Anderson
COMPANY
P.O. Box 1006
Muskogee, OK 74403
918.687.4426