

## UNPACKING

Please open and inspect your package upon receipt. Your package was packed with great care and all the necessary packing materials to arrive to you undamaged. If you do find an item that is broken or damaged, you must contact the delivering carrier to report the claim.

# FIXED DEPTH INSERTION METER INSTRUCTIONS

## GETTING TECHNICAL ASSISTANCE

**The H.E. Anderson Company** is dedicated to assisting our customers with installation and use of our products. Our technical staff are available each weekday from 8:30am to 4:30pm central time. You may call us toll free at **1-800-331-9620** from anywhere in the U.S.A. and Canada. If no one is available, we will promptly return your call.

**Before you call**, we suggest that you review this manual. You may find the answer to your question here. But even if you do not, reviewing the manual will help us to help you.

**There is some information** you should have available when you call. You should know the model and serial number of your control unit. Also, you should note the number of pumpers of each type, and their model numbers (found under the adjustment knob, stamped into the casting). We may not need all this information, but having it available at the start can sometimes save a lot of time and trouble for you.

If you need an additional owners manual for **any** H.E. Anderson Company product, please visit our website at <http://heanderson.com/manuals.php>



## Fixed Depth Insertion Meter

The fixed depth insertion meter uses one moving part - a precision-molded rotor. High-quality jewel bearings and polished carbide shafts minimize friction while providing long wear life in non-lubricating fluids.

Meters properly selected as to size and type will give satisfactory service over a long period of time without maintenance. However, certain operating conditions should be observed. The safe maximum operated capacity (listed below), represents the **maximum** flow which should pass through the meter.

**TABLE 1**

Pipe Size	Flow Range (GPM)
1.5"	1.9 to 190
2"	3.1 to 314
3"	6.9 to 691
4"	12 to 1200
6"	27 to 2700
8"	47 to 4700

## INSTALLATION GUIDELINES

When installing the meter several factors should be considered.

### LOCATION

- Locate for safe and easy access.
- For accurate measurements this meter requires a specific minimum lengths of straight pipe before and after the meter. (See Fitting Installation)

### ENVIRONMENT

- Protect from direct spray and submersion. The electronics enclosure is water resistant but

not water-proof.

- Avoid temperature extremes. Water temperature range is 33°F to 140°F (.5°C to 60°C).
- **Do not allow the meter to freeze.**

## INSTALLATION

**Before installing this meter check local city, state, or government codes to ensure that the proper, required devices (i.e. back flow preventer) are used.**

- We recommend isolation valves before and after the meter to facilitate servicing.
- A by-pass may be necessary if flow cannot be interrupted for servicing. **Be sure the by-pass valve is closed for normal operation.**

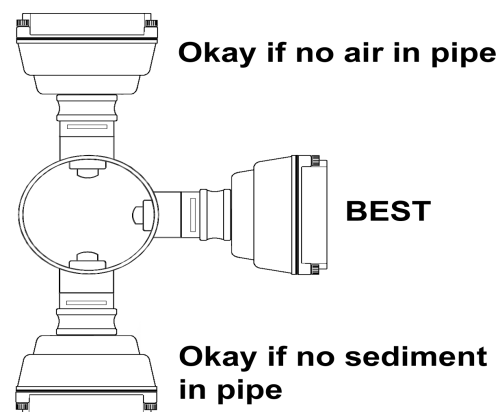

- The meter is all-position, and can be operated in a vertical or horizontal position, and with the water insert in any radial position. A horizontal insert position is preferred if there is a risk of air

becoming trapped due to constant low flows. Operating the meter in a partially-filled pipe will result in inaccuracies.

### Fitting Installation

A PVC fitting is usually installed by solvent welding. The stainless steel and brass meter fittings have female pipe threads, requiring the appropriate male threaded fittings. Saddle fittings (size 3" and above) require a hole to be cut in the pipe. The recommended hole size is 1-3/4". (See Saddle Installation, page. 6)

- Install with a minimum of ten diameters of straight pipe upstream and five downstream. *(It is sometimes possible to operate with less, particularly if the installation includes a flow straightener.)*

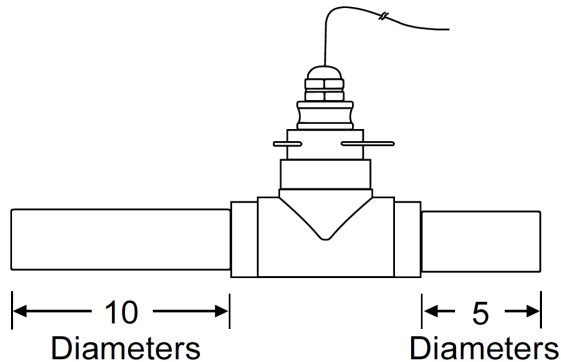

- Refer to the drawing "FLOW METER INSTALLATION REQUIREMENTS" on P.7 for examples of other configurations.
- Take care when threading, or joining pipe that cuttings, pipe dope, solder, or other debris do not get inside of the pipe. Before the meter is placed in service, flush the upstream line to remove any debris.

### Meter Installation

- After the meter fitting is installed

in the pipeline, the meter can be installed into the fitting.

- Point the strain relief either upstream or downstream so the U-pin will line up with the groves in the meter.
- Press the meter into the fitting as far as it will go.
- Retain the meter in place by inserting the U-pin. This pin can be installed from either side. It is sometimes necessary to rotate the probe back and forth slightly to start the pin into the slots on the probe.
- Slide the pin in as far as it will go.

### STARTUP

**K-Factor** - The K-Factor is already factory calibrated and is indicated on the side of the fitting and on the water meter. This represents the actual number of pulses per gallon the meter produced during the factory flow test.

- Set the J Plus controller to the K-Factor according the the controller instructions. *(If you cannot find them call the factory for help at 1-800-331-9620. Instruction manuals are also available on-line at*

<http://heanderson.com/manuals.php>

The following procedure will protect the system from hydraulic shock which often occurs when water suddenly enters a dry meter.

- Before turning on the water, close both isolation valves.
- Turn on the water
- Slowly open the inlet side valve to fill the meter with water.
- Slowly open the outlet side valve fill the system.

### MAINTENANCE

Properly sized meters should require no

maintenance unless there is a malfunction.

**WARNING! If a meter is in an area subject to seasonal subfreezing temperatures it should be removed from service and drained. THE METER IS NOT WARRANTED FOR FREEZE DAMAGE!**

### TROUBLESHOOTING

Troubleshooting the meter is rather simple.

First observe what the two LEDs on top of the meter are doing. One should be on constantly when power to the controller (i.e. J Plus) is present. The other should flash when water is flowing.

If the flow LED appears to be on constantly then slow the water flow. Sometimes the light will flash too fast for the human eye to see.

If the power light is on and the flow light is flashing, there could still be a problem with the small circuit board on the meter.

To verify that it is or isn't the small circuit board you must verify that the J Plus controller is working correctly. To do this,

- Disconnect power to the J Plus.
- Remove the three wires from the small circuit board. There is a bare wire, #1, black wire #2, and a red wire, #3.
- Spread the wires apart so that they are not touching each other or anything else.
- Now, power up the J Plus and touch the #1 wire and the #2 wire together in a tapping motion like "tap-tap-tap-tap". When you are tapping the wires watch the display on the J Plus to see if it is registering flow.
- If it is, then the problem is with the circuit board on top of the

water meter. Order a replacement board, P/N 15231.

- If the display is not registering flow, then the problem is most likely in the wire cable or the J Plus controller. To troubleshoot the J Plus please refer to the J Plus owners manual.

### SERVICING

#### Turbine Insert Removal and Re-installation

- Shut off water and release water pressure.



**Caution!** Never remove the U-clip retainer when the pipe is under pressure. Always remove pressure from the pipe before attempting to remove the meter. Removal under pressure may result in damage or serious injury.

- Pull the U-clip.
- Tug gently on the insert until it comes free. A twisting motion can help to loosen the O-ring seal.
- Replace parts (See below).
- Reverse the procedure to reinstall, after coating the O-ring with a lubricant which is plastics-compatible. *Do not over tighten the screws.* Snug tightening with a hand screwdriver is sufficient.

#### Rotor and Shaft Replacement

- To replace the rotor, use a screwdriver to back the two bearing assemblies out of their threaded holes.
- If replacement is due to shaft wear, the bearing assemblies can be saved and reused. If replacement is due to rotor

damage, the bearings should also be replaced, since they are probably also damaged. The standard "Rotor Repair Kit" (P/N 08964) contains one rotor w/shaft and two bearings.

- To install the rotor, use a blade screwdriver to thread the bearing housings in one or two turns.
- Start the rotor into the slot in the meter insert by tilting it until one end can be entered into the bearing housing hole. Once the rotor is in the slot, screw in one bearing housing.
- Then screw the other bearing in part way. Shake the rotor back and forth to determine clearance before tightening further. **Use caution:** the bearing endstone is hard sapphire, jamming it against the end of the shaft can break it

### Sensor Replacement

The primary cause of sensor failure is over-voltage (inadvertent connection of line voltage, for example) or incorrect polarity on hookup.

- Shut off power to the J Plus controller.
- Loosen strain relief (to J Box)
- Take off blue metal top.
- Remove two screws holding the circuit board.
- Disconnect the sensor wires coming from below the circuit board.

- Remove the bottom of the electronics enclosure held by unscrewing the aluminum retaining nut. (This nut is captive to the enclosure bottom.)
- Unscrew the nylon retaining nut which secures the sensor within the tube.
- Remove the sensor.
- Thread the new sensor cable through the nylon retaining nut.
- Insert the new sensor into the tube and screw in the nylon retaining nut just enough to eliminate play when wiggling the cable.
- Thread the sensor cable through the enclosure bottom and reinstall the bottom onto the meter.
- Connect the sensor wires to the terminal block on the circuit board. Match the numbers on the wires to the numbers on the terminal block. (NOTE: The colors of the sensor wires may not match the colors of the controller wires. Match the numbers, not colors.)
- Reattach the circuit board
- Align the indicator windows in the top with the LEDs on the circuit board and secure the lid.

**Table 2: Flow in gallons per minute at various velocities: Schedule 40 pipe**

Feet / sec. ▼ (0.3)	Nominal Pipe Size														
	1.5"	2"	2.5"	3"	4"	5"	6"	8"	10"	12"	16"	24"	36"	38"	48"
(0.3)	1.9	3.1	4.5	6.9	11.9	18.7	27	46.8	73.7	105	165	376	874	1060	1690
(0.5)	3.2	5.2	7.5	11.5	19.8	31.2	45	78	123	174	275	627	1460	1770	2820
(1.0)	6.3	10.5	14.9	23	39.7	62.4	90	156	246	349	551	1250	2910	3530	5640
(2.0)	12.7	20.9	29.8	46.1	79.4	125	180	312	492	698	1100	2510	5830	7070	11280
(5.0)	31.7	52.3	74.6	115	198	312	450	780	1230	1740	2750	6270	14570	17670	28200
(10.0)	63.5	105	149	230	397	624	900	1560	2460	3490	5510	12530	29140	35350	56400
(20.0)	127	209	298	461	794	1250	1800	3120	4920	6980	11020	25060	58270	70700	112800
(30.0)	190	314	448	691	1190	1870	2700	4680	7370	10470	16520	37600	87410	106050	170000

## Saddle Installation



Place the Saddle on a desired location and mark. Remove saddle, drill hole and deburr.



Place saddle over hole and attach easy clamping hinge around pipe.



Apply wedge half way by hand and finish off with a slight tap of a rubber mallet.

## FLOW METER INSTALLATION REQUIREMENTS

Recommended Number of Pipe Diameters  
(x = Diameters)

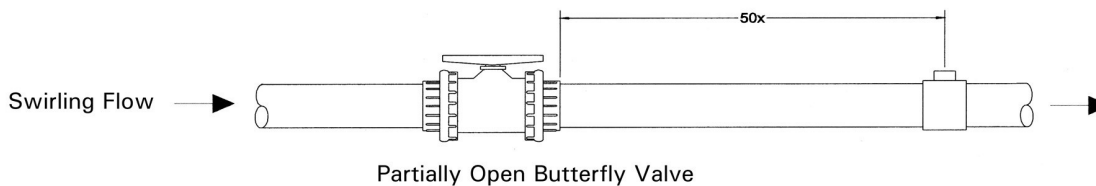
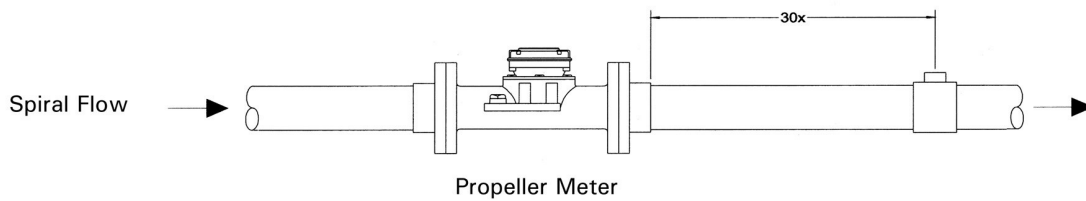
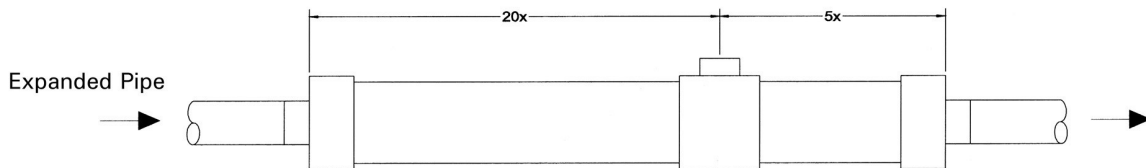
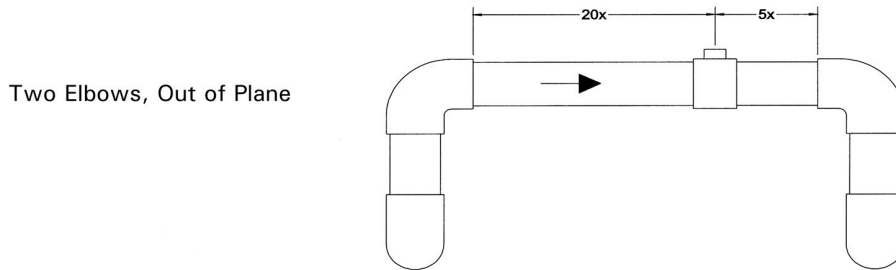
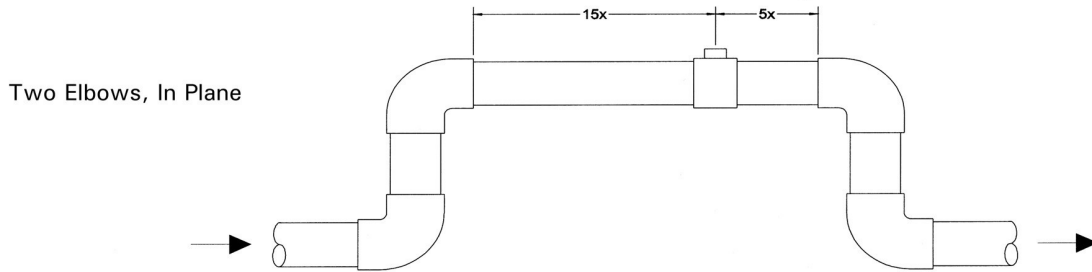
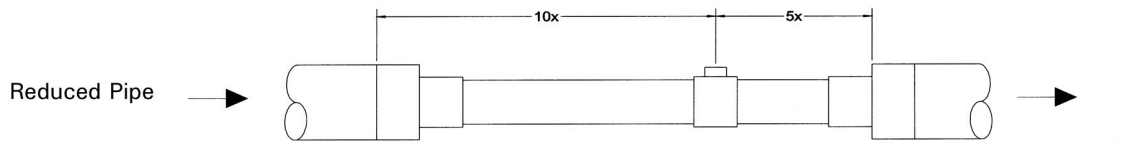

# Fixed Depth Insertion Meter Parts

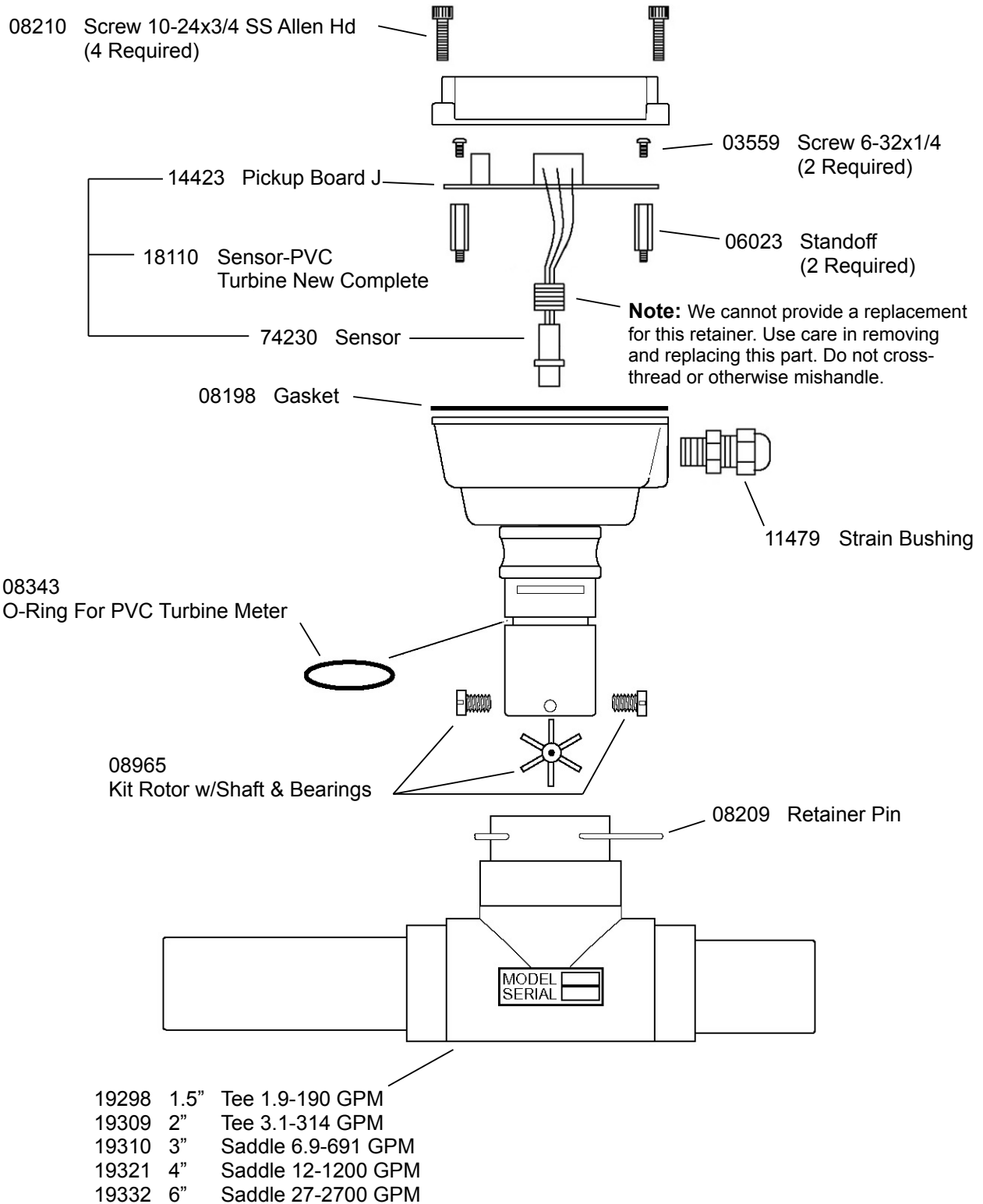



# RATIO:FEEDER® LIMITED WARRANTY

## WHAT IS COVERED

The H.E. Anderson Company of Muskogee, Oklahoma, will make any necessary repairs and/or replace any parts of any Ratio:Feeder® product made necessary because of defects in materials or workmanship for fifteen months from date of manufacture. Warranty repairs and/or replacements will be performed without charge to the owner by H.E. Anderson Company within a reasonable time after prepaid delivery of the defective product to the H.E. Anderson Company, 2100 Anderson Drive, Muskogee, Oklahoma 74403.

## WHAT IS NOT COVERED

This warranty specifically excludes failure of any parts or materials caused by chemical attack or damage caused by operation above rated capacity or pressure. Further, this warranty does not cover wear or failure caused by sand or other foreign materials which may be found in water that is passed through our products, or damage caused by freezing or exposure to water temperatures above 60°C (140°F).

This warranty does not cover damage caused by failure to follow prescribed installation instructions and limitations issued by H.E. Anderson Company. In addition, this warranty does not cover service adjustments, repairs, or replacements caused by misuse, negligence, alteration, accident, or lack of specified maintenance. This warranty does not cover damage to electronics from water, voltage spikes, or lightning strikes.

This warranty does not cover components used by, but not manufactured by H.E. Anderson Company, in the manufacture of our products except to the extent of said component manufacturer's warranty.

This warranty specifically excludes liability for consequential damages or for charges for labor or expense in making repairs or adjustments, or losses of time or inconvenience.

---

This warranty gives you specific legal rights and you may also have other legal rights which may vary from state to state. H.E. Anderson Company does not authorize any person to create for it any other obligation or liability in connection with these products. ANY IMPLIED WARRANTY APPLICABLE TO THESE PRODUCTS IS LIMITED TO THE DURATION OF THIS WARRANTY. H.E. Anderson Company shall not be liable for consequential damages resulting from breach of this written warranty.

NOTE: Some states do not allow limitation on how long an implied warranty will last or the exclusion of limitations of incidental or consequential damages, so the above limitations or exclusions may not apply to you.

---

## WHAT TO DO IF THERE IS A QUESTION REGARDING WARRANTY

- 1) Promptly notify the consumer adviser at H.E. Anderson Company by telephone at 800-331-9620 or 918-687-4426.
- 2) Confirm the report in writing (or via FAX at 918-682-3342) to the H.E. Anderson Company, stating the circumstances surrounding the problem.

## PURCHASER'S OBLIGATION

- 3) Purchaser must give H.E. Anderson Company immediate written notice on discovery of defect.
- 4) Purchaser must pay for shipment of the defective product to the H.E. Anderson Company, 2100 Anderson Drive, Muskogee, Oklahoma 74403.